

PREMIUM

Always Read All Product Literature **BEFORE** installing product.
<https://www.warn.com/manuals/index.jsp>

WARNING

- **Always** position fairlead with warning readily visible on top.
- **Always** use class 8.8 metric (grade 5) or better hardware.
- **Never** weld mounting bolts.
- **Never** use bolts that are too long.
- **Always** confirm required bolt length to ensure proper thread engagement.
- **Always** complete the winch installation and hook attachment before installing the wiring.

Mounting

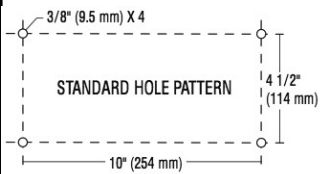
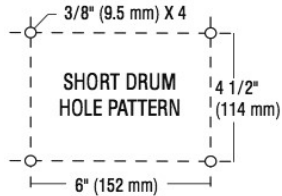
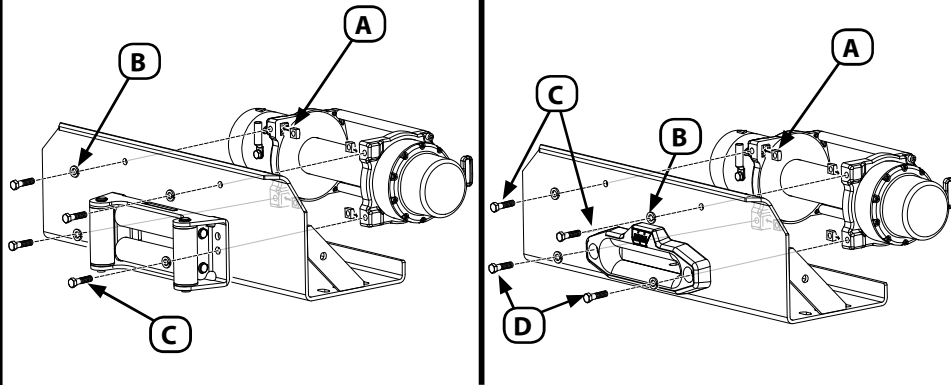

Plate Thickness	Bolt Length
1/4" (7 mm)	1.25" (32 mm)
3/8" (10 mm)	1.5" (40 mm)
1/2" (13 mm)	1.5" (40 mm)



Item	Qty	Description	Item	Qty	Description
A	4	3/8 - 16	A	4	3/8 - 16
B	4	3/8" (9.5 mm)	B	4	3/8" (9.5 mm)
C	4	3/8 - 16 x 1 1/4"	C	2	3/8 - 16 x 1 1/4"
			D	2	3/8 - 16 x 1 1/2"



T 41 to 47 Nm (30-35 ft. lbs.)

Item	Qty	Description	Item	Qty	Description
A	4	3/8 - 16	A	1	Control Pack
B	4	3/8" (9.5mm)	B	1	Bracket
C	4	3/8 - 16 x 1 1/4"	C	2	M6 x 10
			D	1	7/16 - 14 X 1"

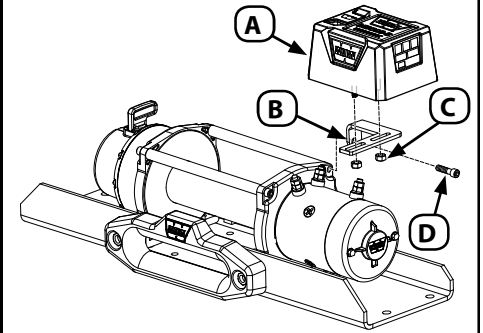
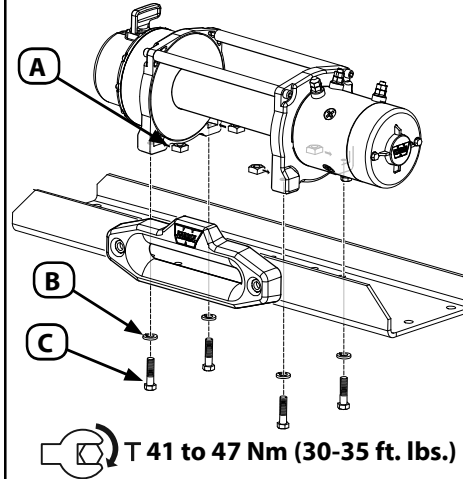

Wiring

WARNING

- **Always** remove jewelry and wear eye protection when making battery connections.
- **Never** route electrical cables across sharp edges.
- **Never** route electrical cables near parts that get hot.
- **Never** route electrical cables over battery terminals.
- **Never** route electrical cables through or near moving parts.
- **Always** insulate and protect all exposed wiring and electrical terminals.
- **Always** place the supplied terminal boots on wires and terminals.

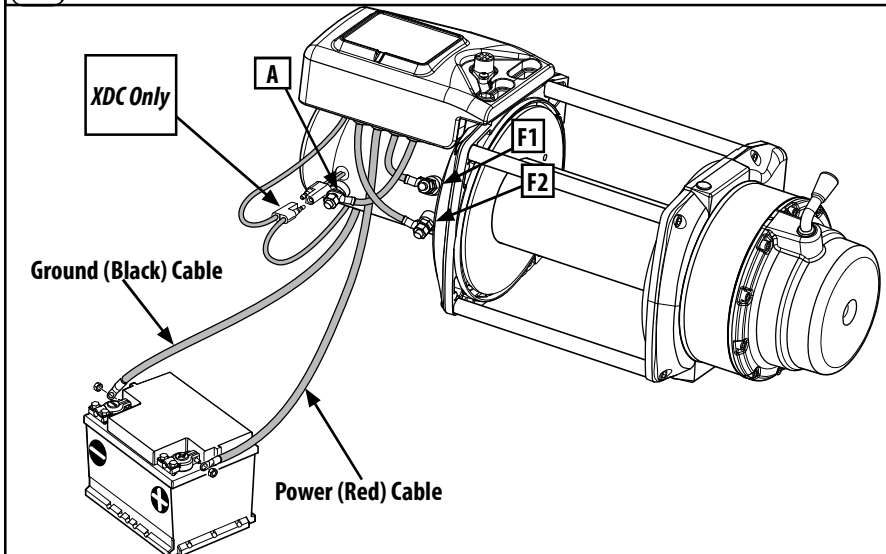

PREMIUM

Lire toute la documentation produit **AVANT** d'installer le produit.

<https://www.warn.com/manuals/index.jsp>

ATTENTION

- **Toujours** placer le guide avec avertissement facilement visible sur le dessus.
- Utilisez **toujours** un matériel de classe 8.8 métrique (grade 5) ou supérieur.
- **Ne jamais** souder les boulons de fixation.
- **N'utilisez jamais** de boulons trop longs.
- **Toujours** vérifier la longueur de boulon requise pour garantir un engagement approprié du filetage.
- Remplissez **toujours** l'installation du treuil et l'attache du crochet avant d'installer le câblage.

Montage

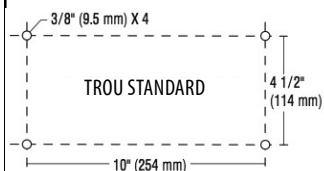
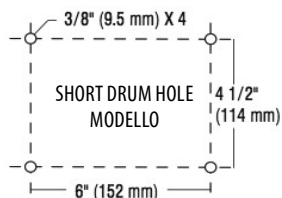
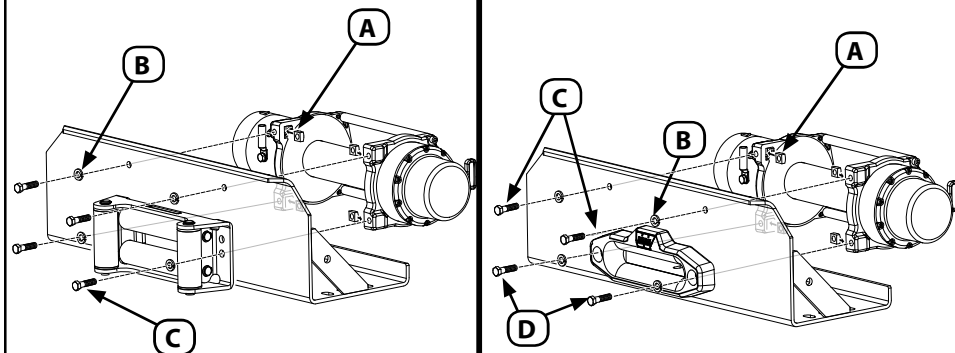

Plate Thickness	Bolt Length
7 mm (1/4")	32 mm
10 mm (3/8")	40 mm
13 mm (1/2")	40 mm



Article	Qté	Description	Article	Qté	Description
A	4	3/8 - 16	A	4	3/8 - 16
B	4	3/8" (9.5 mm)	B	4	3/8" (9.5 mm)
C	4	3/8 - 16 x 1 1/4"	C	2	3/8 - 16 x 1 1/4"
			D	2	3/8 - 16 x 1 1/2"



T 41 to 47 Nm (30-35 ft. lbs.)

98975A0

Article	Qté	Description	Article	Qté	Description
A	4	3/8 - 16	A	1	Control Pack
B	4	3/8" (9.5mm)	B	1	Bracket
C	4	3/8 - 16 x 1 1/4"	C	2	M6 x 10
			D	1	7/16 - 14 X 1"

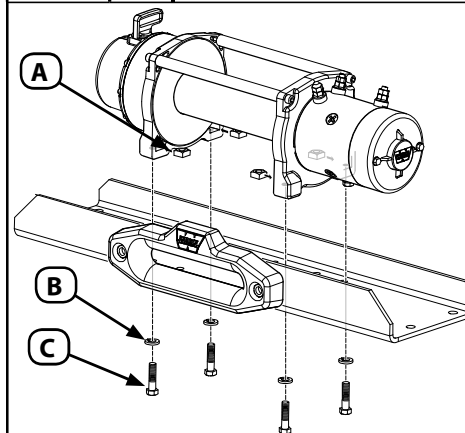

T 41 to 47 Nm (30-35 ft. lbs.)

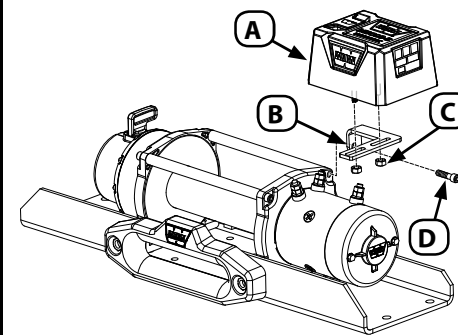

Câblage

AVERTISSEMENT

- **Toujours** retirer les bijoux et porter des lunettes de sécurité.
- **Ne jamais** faire passer les câbles électriques par-dessus des bords tranchants.
- **Ne jamais** faire passer les câbles électriques à proximité de pièces qui s'échauffent.
- **Ne jamais** faire passer les câbles électriques à travers des pièces mobiles ou à proximité.
- **Ne jamais** faire passer les câbles électriques par-dessus les bornes de la batterie.
- **Toujours** isoler et protéger tous les fils et bornes électriques exposés.
- **Toujours** placer les capuchons fournis sur les fils et les bornes.

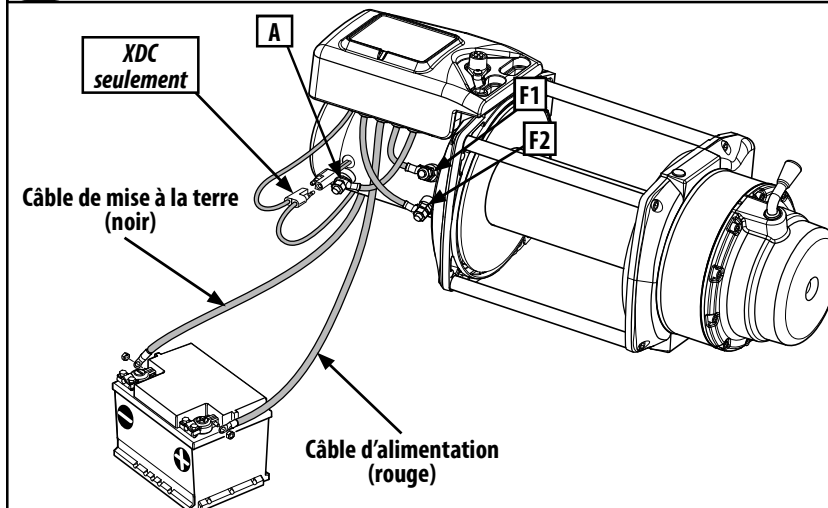

98975A0

PREMIUM



Leer toda la documentación del producto **ANTES** de instalar el producto.
<https://www.warn.com/manuals/index.jsp>

⚠️ ADVERTENCIA

- **Siempre** coloque el manguito con una advertencia visible en la parte superior.
- Utilice **siempre** un hardware de clase 8.8 métrica (grado 5) o superior.
- **Nunca** suelde los pernos de montaje.
- **Nunca** utilice pernos demasiado largos.
- **Siempre** confirme la longitud requerida del perno para asegurar un acoplamiento correcto del hilo.
- **Siempre** complete la instalación del cabrestante y el accesorio de gancho antes de instalar el cableado.

Montaje

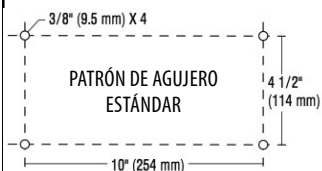
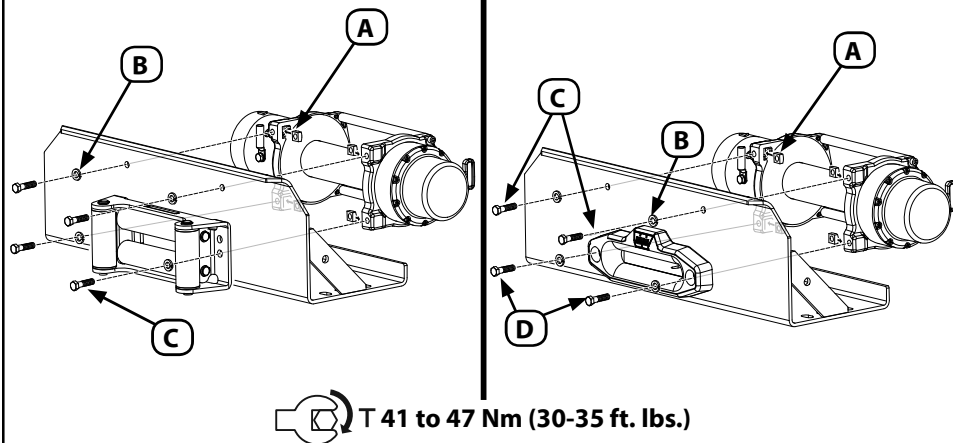

Plate Thickness	Bolt Length
7 mm (1/4")	32 mm
10 mm (3/8")	40 mm
13 mm (1/2")	40 mm



Ít.	Cantidad	Descripción	Ít.	Cantidad	Descripción
A	4	3/8 - 16	A	4	3/8 - 16
B	4	3/8" (9.5 mm)	B	4	3/8" (9.5 mm)
C	4	3/8 - 16 x 1 1/4"	C	2	3/8 - 16 x 1 1/4"
			D	2	3/8 - 16 x 1 1/2"



Ít.	Cantidad	Descripción	Ít.	Cantidad	Descripción
A	4	3/8 - 16	A	1	Control Pack
B	4	3/8" (9.5mm)	B	1	Bracket
C	4	3/8 - 16 x 1 1/4"	C	2	M6 x 10
			D	1	7/16 - 14 X 1"

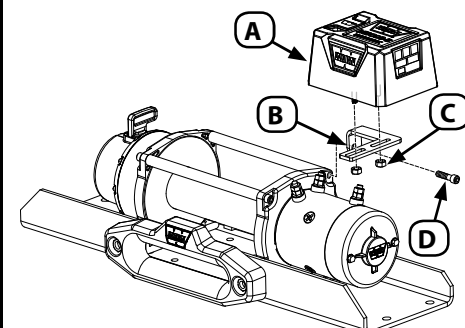
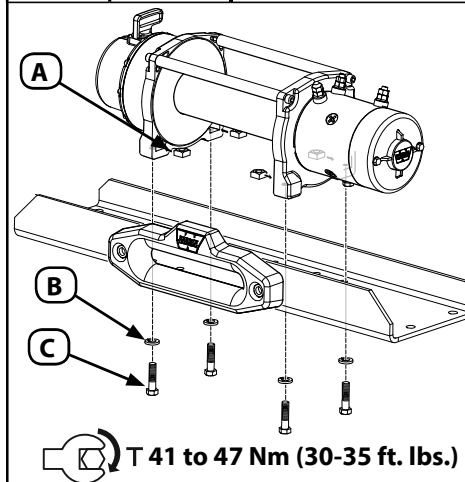

Alambrado

⚠️ AVERTISSEMENT

- **Siempre** quite las joyas y use protección para los ojos cuando realice las conexiones de la batería.
- **Nunca** enrute cables eléctricos a través de bordes afilados.
- **Nunca** enrute los cables eléctricos cerca de las piezas que se calientan.
- **Nunca** ponga los cables eléctricos sobre los terminales de la batería.
- **Nunca** enrute cables eléctricos a través o cerca de partes móviles.
- Aislar y proteger **siempre** todo el cableado expuesto y los terminales eléctricos.
- Coloque **siempre** las boquillas de terminal suministradas en los cables y terminales.

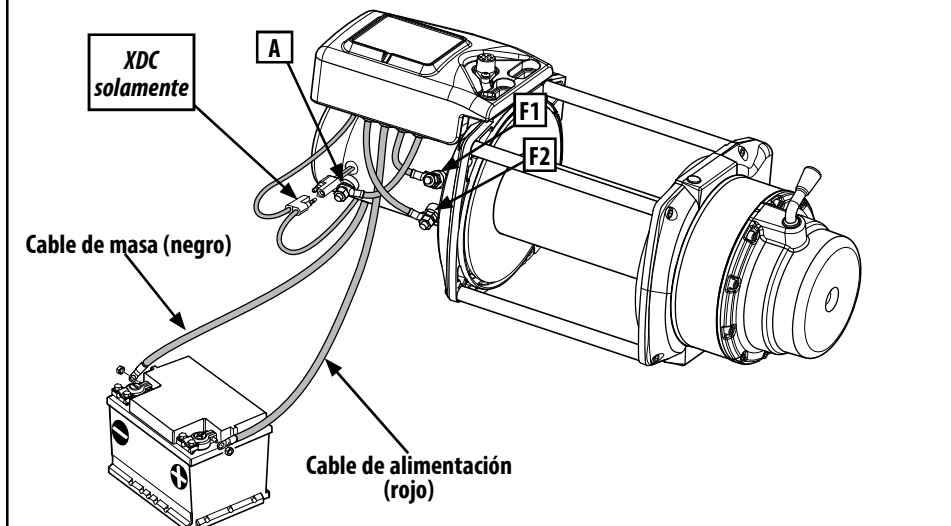



(Deutsch) Bitte besuchen <https://www.warn.com/manuals/index.jsp> für Installationsanleitung.

(Svenska) Besök <https://www.warn.com/manuals/index.jsp> för Installera instruktioner.

(Italiano) Visitare <https://www.warn.com/manuals/index.jsp> per installare istruzioni.

(Suomi) Vieraille <https://www.warn.com/manuals/index.jsp> asennusohje.

(Nederlands) Bezoek <https://www.warn.com/manuals/index.jsp> voor installatiehandleiding.

(Português) Visite <https://www.warn.com/manuals/index.jsp> para guia de instalação.

WARN INDUSTRIES, INC. 12900 S.E. Capps Road,
Clackamas, OR USA 97015-8903, 1-503-722-1200, FAX: 1-503-722-3000
Customer Service: 1-800-543-9276
Dealer Locator Service: 1-800-910-1122
International Fax: 1-503-722-3005